

EmPower HD-coax Series

◆ HC-2BL-MVF-PA ◆

2 Megapixel Starlight
HD-coax IR Bullet Camera

Features

- ◆ Starlight, 120dB true WDR, 3DNR
- ◆ Max 30fps@1080P
- ◆ HD and SD output switchable
- ◆ 2.7-13.5mm motorized lens
- ◆ Max. IR length 60m, Smart IR
- ◆ IP67, AC24V/DC12V



System Overview

Experience 1080P full HD video and the simplicity of reusing existing coaxial infrastructure with HD-over-coax. The Starlight HD-over-coax camera with 120dB true WDR presents a high quality image with rich details even in extreme low-light conditions. It offers various motorized/fix lens models with a multi-language OSD and HD/SD switchable output. Its superior image performance and starlight feature makes the camera an ideal choice for mid to large-size businesses and projects where both highly reliable surveillance and construction flexibility are needed.

Functions

4 Signals over 1 Coaxial Cable

HD-over-Coax technology supports 4 signals to be transmitted over 1 coaxial cable simultaneously, i.e. video, audio*, data and power. Dual-way data transmission allows the HD-over-Coax camera to interact with the HCVR, such as sending control signal or triggering alarm. Moreover, HD-over-Coax technology supports PoC for construction flexibility.

* Audio input is available for some models of HD-over-Coax cameras.

Long Distance Transmission

HD-over-Coax technology guarantees real-time transmission at long distance without any loss. It supports up to 800m(1080P)/1200m(720P) transmission via coaxial cable, and up to 300m(1080P)/450m(720P) via UTP cable.*

*Actual results verified by real-scene testing in Unisight's test laboratory.

Simplicity

HD-over-Coax technology inherits the born feature of simplicity from traditional analog surveillance system, making itself a best choice for investment protection. HD-over-Coax system can seamlessly upgrade the traditional analog system without replacing existing coaxial cabling. The plug and play approach enables full HD video surveillance without the hassle of configuring a network.

Smart IR

The camera is designed with microcrystalline LED IR illumination for best lowlight performance. Smart IR is a technology to ensure brightness uniformity in B/W image under low illumination. The unique Smart IR adjusts to the intensity of camera's infrared LEDs to compensate for the distance of an object, and prevents IR LEDs from overexposing images as the object come closer to the camera.

Starlight

With the adoption of high performance sensor, the camera is able to provide incomparable performance even under extreme lowlight environment. The starlight feature allows more details to be captured and accurate color to be recognized at night or in scenes with limited illumination.

Wide Dynamic Range

Embedded with industry leading wide dynamic range (WDR) technology, vivid pictures are achieved even in the most intense contrast lighting conditions. True WDR (120dB) optimizes both the bright and dark areas of a scene at the same time to provide usable video.

Advanced 3DNR

3DNR is noise reduction technology that detects and eliminates random noises by comparing two sequential frames. The advanced 3DNR technology allows remarkable noise reduction with little impact to sharp ness, especially under limited lighting condition. Besides, the advanced 3DNR effectively decreases the band width and saves the storage space.

Multi-formats

The camera supports multiple video formats including HDCVI, CVBS and other two common HD analog formats in the market. The four formats can be switched over through OSD menu or by PFM820 (UTC controller). This feature makes the camera to be compatible with not only HCVRs but also most end users' existing HD/SD DVRs.

Large Aperture Lens

The camera adopts high-end F1.3 large aperture lens. With higher amount of absorbed light, the camera presents an impressive lowlight performance.

Protection

The camera's outstanding reliability is unsurpassed due to its rugged design. The camera is protected against water and dust with IP67, making it suitable for indoor or outdoor environments. The camera complies with IK10 impact resistant rating to provide maximum durability against vandals, making it capable of withstanding the equivalent of 55kg (120lbs) of force. Supporting $\pm 25\%$ input voltage tolerance, this camera suits even the most unstable power supply conditions. Its 4KV lightning rating provides protection against the camera and its structure from the effects of lightning.

◆ HC-2BL-MVF-PA ◆

Technical Specification

Camera

Image Sensor	1/2.8" CMOS
Effective Pixels	1937(H)×1097(V), 2.1MP
Scanning System	Progressive
Electronic Shutter Speed	PAL: 1/4s~1/100000s NTSC: 1/3s~1/100000s
Minimum Illumination	0.005Lux/F1.3, 30IRE, 0Lux IR on
S/N Ratio	More than 65dB
IR Distance	Up to 60m (197feet)
IR On/Off Control	Auto / Manual
IR LEDs	4

Lens

Lens Type	Motorized lens / Fixed iris
Mount Type	Board-in
Focal Length	2.7-13.5mm
Max Aperture	F1.3
Angle of View	H: 102°~29°
Focus Control	Auto / Manual
Close Focus Distance	200mm 7.87"

DORI Distance

*Note: The DORI distance is a "general proximity" of distance which makes it easy to pinpoint the right camera for your needs. The DORI distance is calculated based on sensor specification and lab test result according to EN 62676-4 which defines the criteria for Detect, Observe, Recognize and Identify respectively.

		Distance	
		Wide	Tele
Detect	25px/m (8px/ft)	47m(154ft)	153m(502ft)
Observe	63px/m (19px/ft)	19m(62ft)	61m(200ft)
Recognize	125px/m (38px/ft)	9m(30ft)	31m(102ft)
Identify	250px/m (76px/ft)	5m(16ft)	15m(49ft)

Pan / Tilt / Rotation

Pan/Tilt/Rotation	Pan: 0° ~ 360° Tilt: 0° ~ 87° Rotation: 0° ~ 360°
-------------------	---

Video

Resolution	1080P (1920×1080)
Frame Rate	25/30fps@1080P, 25/30fps@720P
Video Output	1-channel BNC high definition video output / CVBS video output (Can switch)

Day/Night	Auto (ICR) / Manual
OSD Menu	Multi-language
BLC Mode	BLC / HLC / WDR
WDR	120dB
Gain Control	AGC
Noise Reduction	2D / 3D
White Balance	Auto / Manual
Smart IR	Auto / Manual

Certifications

Certifications	CE (EN55032, EN55024, EN50130-4) FCC (CFR 47 FCC Part 15 subpartB, ANSI C63.4-2014) UL (UL60950-1+CAN/CSA C22.2 No.60950-1)
----------------	---

Interface

Audio Interface	N/A
-----------------	-----

Eelectrical

Power Supply	AC 24V±25%/DC 12V±25%
Power Consumption	Max 14.1W (12V DC, IR on)

Environmental

Operating Conditions	-40°C ~ +60°C (-40°F ~ +140°F) / Less than 90% RH * Start up should be done at above -40°C (-40°F)
Storage Conditions	-40°C ~ +60°C (-40°F ~ +140°F) / Less than 90% RH
Ingress Protection & Vandal Resistance	IP67

Construction

Casing	Aluminium
Dimensions	222mm×96.1mm×90.4mm(8.74"×3.78"×3.56")
Net Weight	0.63kg (1.39lb)
Gross Weight	0.76kg (1.68lb)

EmPower HD-coax Series

◆ HC-2BL-MVF-PA ◆

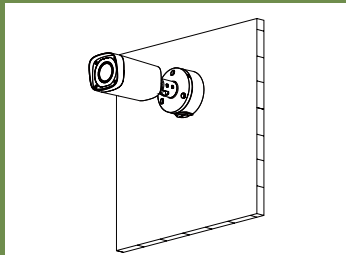

PFA130-E

Junction Mount

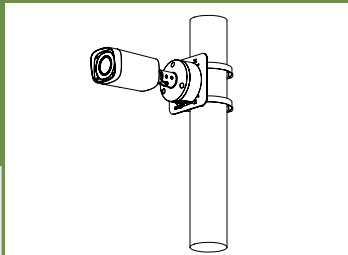

PFA130-E+PFA152-E

Pole Mount

Dimensions(mm/inch)

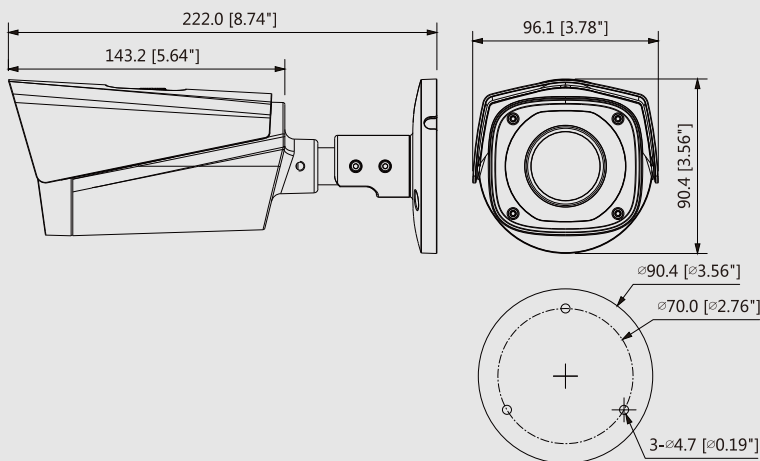

Accessories

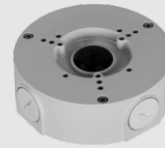

PFA130-E
Junction Box



PFA152-E
Pole Mount



PFM820
UTC Controller



PFM800-E
Passive
HD-coax Balun



PFM800-4MP
Passive
HD-coax Balun



PFM801-4MP
Passive
HD-coax
Balun with Power



PFM809-4MP
16Channel Passive
HD-coax Balun Receiver



PFM321
12V/1A
Power Adapter



PFM320
12V/2A
Power Adapter



PFM320D-015
Power Adapter